

# 2021 LINE UP



\*EFFECTIVE FEBRUARY 15, 2021

## ALFA OVENS



Double layer of **high quality European Ceramic Fiber** that completely surrounds the oven and resistant up to 2000°F.

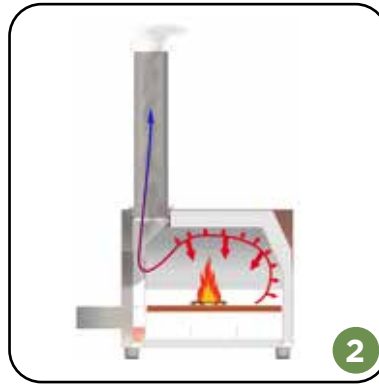

Alfa's unique baffled **airflow system** provides more circulation of flame and heat allowing the oven **to reach higher temps much faster.**



**3 cm of Alfa refractory brick**, made 100% in house provides **better heat absorption and retention than the competition.**

## OTHER BRANDS



**Commercial Rock Wool insulation** is less dense and looser fiber and only resistant up to 1100°F.

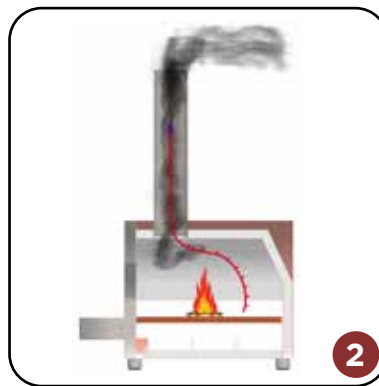

Generic flue system allows the **heat and flame to escape the oven chamber immediately** requiring more time to reach desired temperatures.



Commercial grade mix comparable to dense lava stone demands **longer time for heat absorption and retention.**



ONE, the smallest oven in the category!  
 The real **Italian portable pizza oven**.  
 Compact and fast to use with the highest  
 Italian professional quality.

# ONE



FXONE-LRAM



FXONE-GRAM  
 &  
 BF-ONE-RAM

### Technical Details

- Heating time: 10 minutes
- Recommended fuel: Wood or lump charcoal
- Max oven temperature: 1,000°F +
- Chimney dimensions: 5.0"
- Cooking Floor W x D: 23.6" x 15.7"
- Weight: 110 lbs

Mini Peel and Wood Holder included

### GAS MODEL is COMING SOON

- Recommended fuel: LPG gas or Natural Gas
- Max oven temperature: 1,000°F +
- Heat Capacity: 30,000 BTU/hr
- Chimney dimensions: 5.0"
- Cooking Floor W x D: 19.6" x 15.7"
- Weight 120 lbs

Mini Peel included

**Base** has stainless-steel front panel, black handle and 4 professional casters with brakes. Weighs as little as 55 lbs and is available in Copper or Silver black.

Model	Description	Finish
FXONE-LRAM	Wood Top Only	Copper
FXONE-GRAM	Gas Top Only	Copper
BF-ONE-RAM	Base	Copper
BF-ONE-SBL	Base	Silver Black

### Dimensions

A	29"
B	22"
C	41"
D	19"
E	5"
F	8"

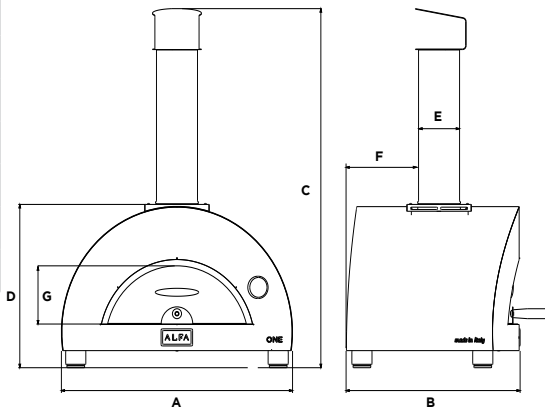

### Dimensions

A	34.6"
B	33.6"
C	17.2"
D	28.2"
E	31.9"
F	18.8"
G	3"
H	7.8"
I	4.7"

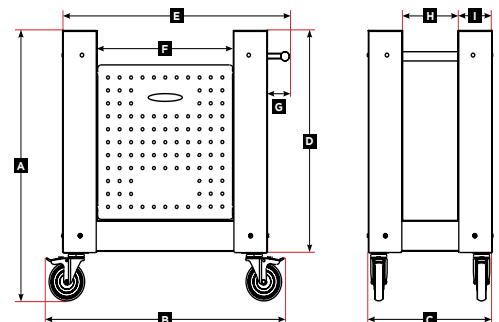



# CIAO<sub>m</sub>

Performs very well in small spaces



FXCM-LGRI-T-V2

Technical Details	
• Heating time:	10-20 minutes
• Recommended fuel:	Wood or lump charcoal
• Max oven temperature:	1,000°F +
• Chimney dimensions:	5.9"
• Cooking Floor W x D:	27.6" x 15.7"
• Cooking Floor Height:	35"
• Oven Mouth width:	19.7"
• Weight:	Top only 176 lbs



FXCM-LGIA-T-V2  
&  
BF-CIAOM-GR

Model	Description	Finish
FXCM-LGIA-T-V2	Top Only	Fire Yellow
FXCM-LGRI-T-V2	Top Only	Silver Gray
BF-CIAOM-GR	Leg Kit	Silver Gray
BF-CIAOM	Leg Kit	Stainless Steel

Dimensions	
A	35.9"
B	25.0"
C	46.5"
D	19.7"
E	8.1"
F	5.9"
G	10.2"
H	18.9"

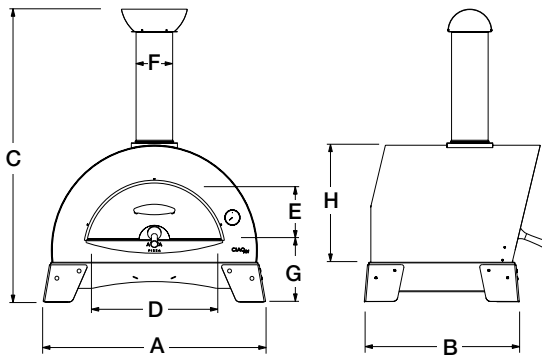

Dimensions	
A	46.4"
B	33.5"
C	71.2"
D	19.7"
E	8.1"
F	5.9"
G	35.0"
H	18.9"

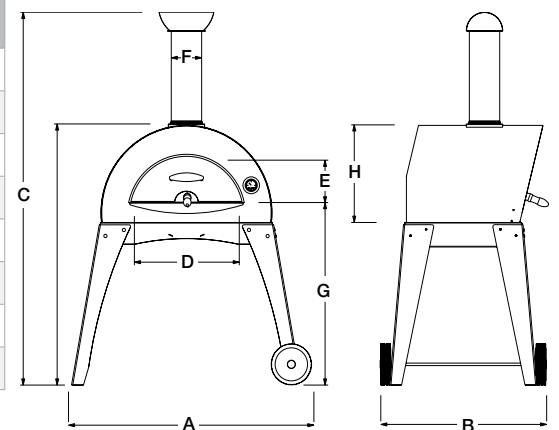

# 5 MINUTI

The Original



FX5MIN-LRAM-T

### Technical Details

- Heating time: 10-20 minutes
- Recommended fuel: Wood or lump charcoal
- Max oven temperature: 1,000°F +
- Chimney dimensions: 5.9"
- Cooking Floor W x D: 23.6" x 19.7"
- Cooking Floor Height: 31.5"
- Oven Mouth width: 18.0"
- Weight: Top only 160 lbs

**Base** has a shelf for wood storage, stainless-steel front panel, black handle and 4 professional casters with brakes. Weighs as little as 64 lbs and is available in Copper or Silver black.



FX5MIN-LRAM-T  
&  
BF-5MINUTI-RAM

Model	Description	Finish
FX5MIN-LRAM-T	Top Only	Copper
BF-5MINUTI-RAM	Base	Copper
BF-5MINUTI-SBL	Base	Silver Black

Dimensions	
A	32.5"
B	26.8"
C	47.6"
D	18.1"
E	9.8"
F	5.9"
G	20.8"

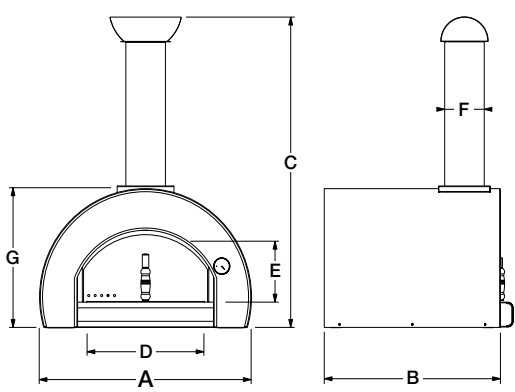

Dimensions	
A	34.6"
B	35.9"
C	25"
D	28.2"
E	33.5"
F	21.2"
G	3"
H	15.5"
I	4.7"

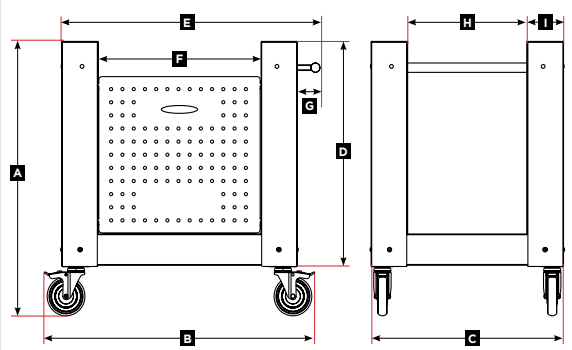



# 4 PIZZE

The worldwide bestseller

The design and performance of our 4 Pizze has everyone talking. It's our best seller, worldwide. The lateral shelves and peel hooks make it practical and simple. The 4 Pizze is ideal for anyone who loves wood cooking.



FX4P-LRAM-T



FX4PIZ-LRAM

### Technical Details

- Heating time: 10-20 minutes
- Recommended fuel: Wood or lump charcoal
- Max oven temperature: 1,000°F +
- Chimney dimensions: 5.9"
- Cooking Floor W x D: 31.5" x 23.6"
- Cooking Floor Height: 36.0"
- Oven Mouth width: 26.7"
- Weight: Top only 264 lbs - with base 308 lbs

Model	Description	Finish
FX4P-LRAM-T	Top Only	Copper
FX4PIZ-LRAM	Oven with Base	Copper

Dimensions	
A	26.7"
B	39.3"
C	8.6"
D	26.3-26.7"
E	30.2"
F	38.1"
G	9.2-9.6"
H	47.6-48.0"
I	5.9"

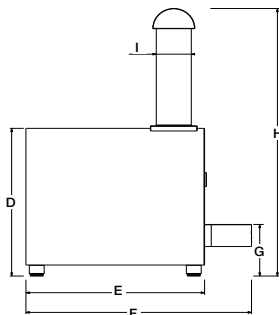
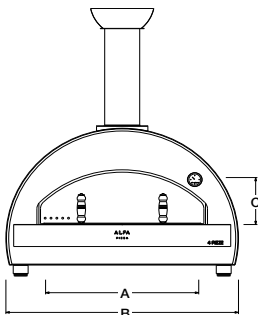

Dimensions	
A	61.0"
B	34.4"
C	79.5"
D	26.7"
E	8.6"
F	5.9"
G	36.0"
H	10.8"

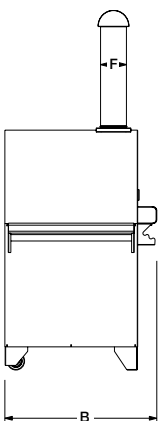
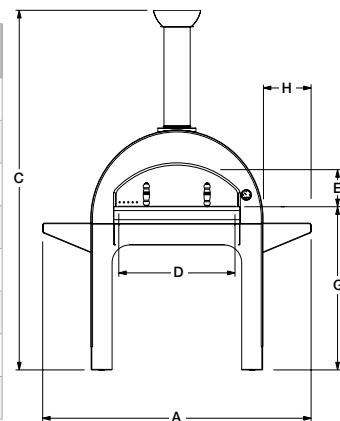

Brio at last!  
 Here's the new Alfa Forni's 2-pizza gas-fired oven.  
 Brio is the oven that heats up so quickly that you  
 can eat your first pizza in just 30 minutes.

# BRIO



FXBRIO-GROA-U

### Technical Details

- Heating time: 20 minutes
- Recommended fuel: LPG gas or Natural Gas
- Max oven temperature: 1,000°F +
- Heat Capacity: 71,000 BTU/hr
- Chimney dimensions: 5.9"
- Cooking Floor W x D: 27.5" x 19.7"
- Oven Floor Area: 3.77 ft<sup>2</sup>
- Weight: Top only 215 lbs

**Base** has a stainless-steel front panel to hide LPG tank, black handle and 4 professional casters with brakes. Weighs as little as 70 lbs and is available in Silver black.



FXBRIO-GROA-U  
 &  
 BF-BRIO-SBL

Model	Description	Finish
FXBRIO-GROA-U	Gas Top Only	Antique Red
BF-BRIO-SBL	Base	Silver Black

Dimensions			
A	39.25"	N	9.3"
B	28.6"	O	16.2"
C	43.9"	P	12.4"
D	22.6"	Q	19.6"
E	5.9"	R	34"
F	21.3"	S	2.7"
G	19.6"	T	19.7"
H	7"	U	6.6"
L	16.8"	V	2.3"
M	13.2"	Z	30.2"

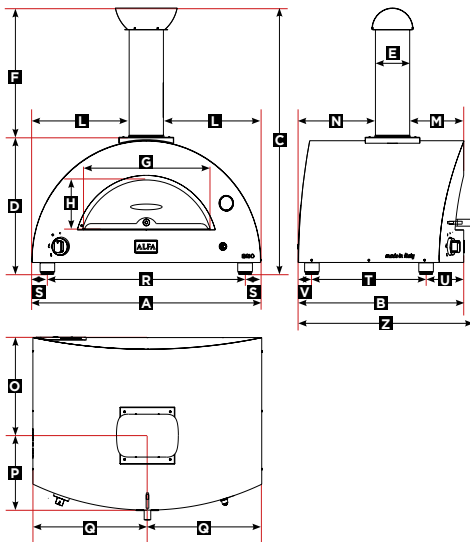

Dimensions	
A	34.6"
B	41.5"
C	25"
D	28.2"
E	39.2"
F	26.8"
G	3"
H	15.7"
I	4.7"

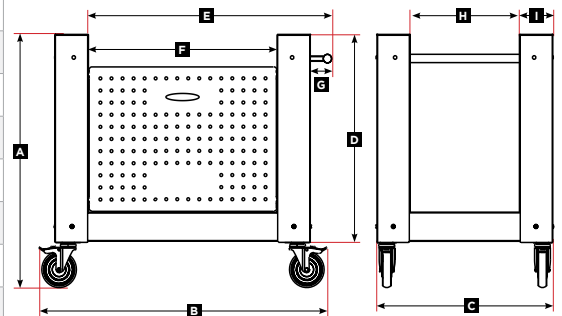



# STONE



FXSTONE-L

### Stone Oven Technical Details

- Heating time: 30-40 minutes
- Recommended fuel: LPG gas or Natural Gas
- Max oven temperature: 1,000°F +

#### STONE-L

- Heat Capacity: 83,000 BTU/hr
- Chimney dimensions: 7.0"
- Cooking Floor W x D: 31.5" x 23.6"
- Oven Floor Area: 5.16 ft<sup>2</sup>
- Weight 312 lbs

#### STONE-M

- Heat Capacity: 70,000 BTU/hr
- Chimney dimensions: 5.1"
- Cooking Floor W x D: 27.6" x 15.7"
- Oven Floor Area: 3.0 ft<sup>2</sup>
- Weight 276 lbs

Model	Description	Finish
FXSTONE-M	Medium Gas Oven	Copper
FXSTONE-L	Large Gas Oven	Copper

Dimensions	
A	43.4"
B	32.9"
C	59.4"
D	27.7"
E	5.9"
F	15.6"

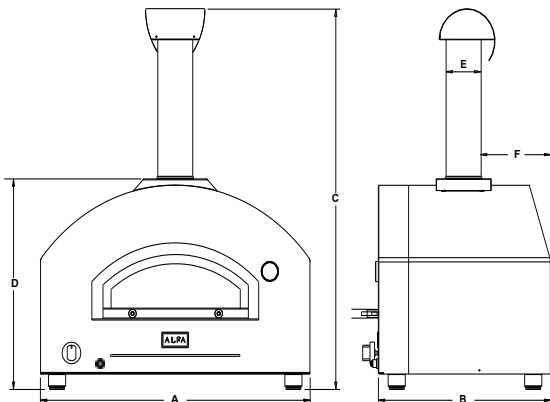

FXSTONE-L

Dimensions	
A	39.4"
B	25"
C	48.4"
D	26.8"
E	5.1"
F	10.2"

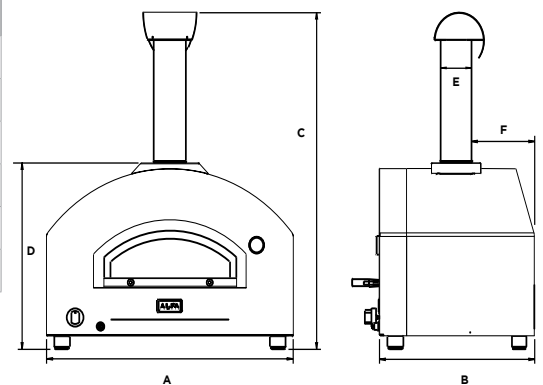

FXSTONE-M



# ALLEGRO

High performance, big size



FXALLE-LGIA-T

### Technical Details

- Heating time: 20 minutes
- Recommended fuel: Wood or lump charcoal
- Max oven temperature: 1,000°F +
- Chimney dimensions: 7.0"
- Cooking Floor W x D: 39.4" x 27.6"
- Cooking Floor Height: 37.4"
- Oven Mouth width: 23.2"
- Weight: Top only 308 lbs - with base 485 lbs



FXALLE-LROA

Model	Description	Finish
FXALLE-LROA-T	Top Only	Antique Red
FXALLE-LGIA-T	Top Only	Fire Yellow
FXALLE-LROA	Oven with Base	Antique Red
FXALLE-LGIA	Oven with Base	Fire Yellow

Dimensions	
A	46.4"
B	40.0"
C	57.5"
D	23.2"
E	7.4"
F	7.0"
G	23.8"

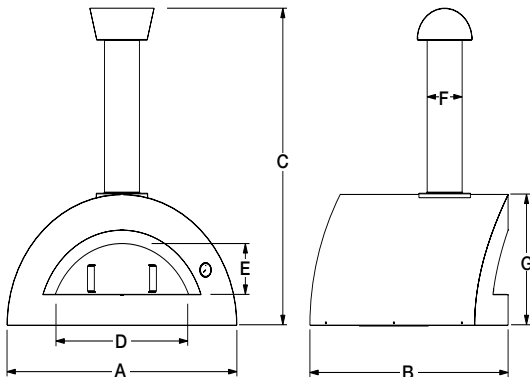

Dimensions	
A	46.4"
B	40.0"
C	88.6"
D	23.2"
E	7.4"
F	7.0"
G	37.4"
H	27.5"

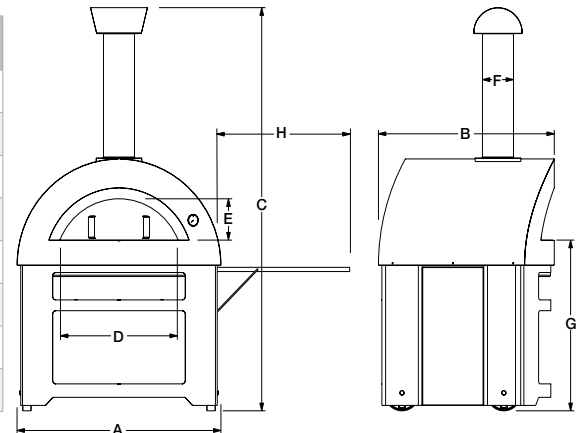



# CUPOLINO

## ALFA REFRACTORY SERIES

Cupolino is the wood fired oven you can build and customize. Size 60 is composed of 2 pieces, sizes 70 and 80 are composed of 3 pieces. Cupolino is easy to assemble. It is light, strong and hand crafted using the best refractory materials available. Cupolino is the perfect wood fired oven for DIY lovers. It's small size means that it heats up very quickly, it is ready in only 45 minutes. It also comes with a steel arched door with double handle. Not UL certified for indoor installation.



Shown Installed With Custom Tiles

### Technical Details

Available in three sizes 60, 70, 80

- Heating time: 45 minutes
- Pizza capacity: 2, 3, 4
- Bread capacity: 8.0 lbs, 13.2 lbs, 17.0 lbs
- Recommended fuel: Wood or lump charcoal
- Max oven temperature: 1,000°F +
- Oven Mouth Height: 9.4"
- Oven Floor Area: 3.0 ft<sup>2</sup>, 4.0 ft<sup>2</sup>, 5.4 ft<sup>2</sup>
- Weight 198 lbs, 286 lbs, 319 lbs

### NOT FOR USE "AS IS" OUT OF THE CRATE

Cupolino is designed to be used as the insert for custom brick or stone masoned outdoor oven projects.

Model	Description
FRCUP-L60	60cm / 23.6"
FRCUP-L70	70cm / 27.5"
FRCUP-L80	80cm / 31.5"

Dimensions			
A	27.5"	31.5"	35.4"
B	33.4"	35.4"	40.9"
C	15.7"	17.7"	19.7"
D	18.1"	18.5"	18.1"
E	9.4"	9.4"	9.4"
F	23.6"	27.5"	31.5"

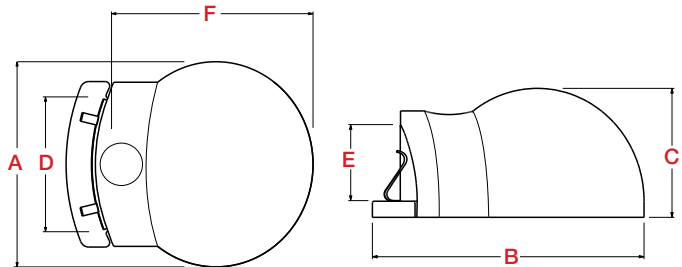

# TABLE

## Multi-functional base and Prep Station

The world's most versatile oven now has a cooking station to complement it. A multi-functional table that provides an area for preparation and cooking. It is designed for convenience as well as aesthetics. High quality details provide you with a premium surface you need to prepare your meals!



### Technical Details

- 304 stainless steel 2mm working top
- Peel Holder
- Bottle Opener
- 3 stainless steel hooks for tools
- Aluminum black handle
- 4 Professional wheels with 2 brakes
- Compatible with: ONE, Ciao, 5 Minuti, 4 Pizze, Stone and Allegro.
- Available in three sizes:
  - 40"W x 35.2"H x 31.5"D
  - 51"W x 35.2"H x 35.4"D
  - 63"W x 35.2"H x 35.4"D

Check out the video link below to see just how easy the assembly is.

<https://vimeo.com/295796645>

Model	Description	Finish
ACTAVO-100*	40"W Table	Stainless Steel
ACTAVO-130	51"W Table	Stainless Steel
ACTAVO-160	63"W Table	Stainless Steel

\*does not have bottle opener or hooks





# Cooking Tools



Technical Details
<ul style="list-style-type: none"> <li>• Pizza peel to put the pizza in the oven, with its wooden handle and stainless steel structure, guarantees robustness, cleanliness and easy-handling. Its rounded edge makes putting pizza in the oven a snap.</li> <li>• Pizza turner/round peel is lightweight, sturdy and easy to handle.</li> <li>• Ember Rake allows you to prepare the oven floor and to move the ash, embers and burning wood to the side.</li> <li>• Brush is equipped with brass bristles which make for effective cleaning and more importantly, preserving the refractory floor.</li> <li>• The tools are available in two sizes. 36" and 48"</li> </ul>



Model	Description
AFISETP90	4 Piece Peel Set - 36"
AFISETP125	4 Piece Peel Set - 48"
AFI2PKSET90	2 Pack Pizza Turner/Brush - 36"
AFI2PKSET120	2 Pack Pizza Turner/Brush - 48"
AC-PALA90	Pizza Peel - 36"
AC-PALINO90	Pizza Turner - 36"
AC-MUOVIB90	Ember Rake - 36"
AC-SPAZZ90	Brush - 36"
AC-PALA120	Pizza Peel - 48"
AC-PALINO120	Pizza Turner - 48"
AC-MUOVIB120	Ember Rake - 48"
AC-SPAZZ120	Brush - 48"
AFIPOPAL-RA	Vela Peel Holder - Copper

36" is recommended for the ONE, Ciao & 5 Minuti  
48" is recommended for all other ovens

# Accessories



Kit Pizzaiolo



BBQ500



Wood Holder

## Technical Details

- The Pizzaiolo Kit includes all the tools necessary for making pizza: peel, round peel, ember rake, oven brush, dough ball proofing box, laser thermometer, wheel cutter, dough cutter, apron, chopping board, heat-resistant glove and cookbook. All the tools in the kit are made in Italy and certified for food use. The wooden tools are entirely handmade and selected according to high quality standards. Available in 2 sizes. 36" and 48"
- The BBQ500 easily turns your oven into a BBQ with four heat sources.
- The Wood Holder is made to hold the cooking wood and embers laterally, allowing for air flow and optimal fire/heat and keeps the cooking floor clean. Available in 2 sizes.



Cooking wood



Firestarter

Model	Description
KITPIZ-90	Kit Pizzaiolo - 36"
KITPIZ-125	Kit Pizzaiolo - 48"
AC-BBQ500-3	BBQ 500 D37
AC-BOX	Proofing Box
HYB-01-005	Wood Holder L37
PLP-01-600	Wood Holder L59
OAKWOOD	Cooking Wood
APPLEWOOD	Cooking Wood
CHERRYWOOD	Cooking Wood
CHERRYWOOD-SMALL	Cooking Wood*
QWIKWIK	Firestarter

\*small pieces for a better fit in ONE oven

HYB-01-005 is recommended for the Ciao & 5 Minuti  
 PLP-01-600 is recommended for all other ovens

# Covers



4 Pizze with base cover

## Technical Details

- The form-fitting oven cover is specially designed to protect your oven from the elements when not in use. This cloth is made of an innovative material which is waterproof, breathable (prevents condensation), thermal and UV ray resistant.

Model	Description
CVR-ONE	Cover for ONE Top Only
CVR-CIAO-T	Cover for Ciao M Top Only
CVR-5MIN-T	Cover for 5 Minuti Top Only
CVR-4PIZ-T	Cover for 4 Pizze Top Only
CVR-STN-M	Cover for Stone M Top Only
CVR-STN-L	Cover for Stone L Top Only
CVR-ALLE-T	Cover for Allegro Top Only
CVR-CIAO	Cover for Ciao M with base
CVR-5MIN	Cover for 5 Minuti with base
CVR-4PIZ	Cover for 4 Pizze with base
CVR-ALLE	Cover for Allegro with base



**PATIO TOWN**  
**[www.patiotown.com](http://www.patiotown.com)**

6300 Hwy 36  
**OAKDALE**  
(651) 770-1391

8500 Jefferson Ln. N  
**BROOKLYN PARK**  
(763) 488-1300

2801 Hwy 13 West  
**BURNSVILLE**  
(952) 894-4400